

# Quick Reference Guide

To find full instructions for the different functions of the Husqvarna Opal 650, see the User's Guide. This guide is designed only to aid in the use of the Opal 650, not to cover the entire process of using the machine.

## Reading the Husqvarna Functions Panels

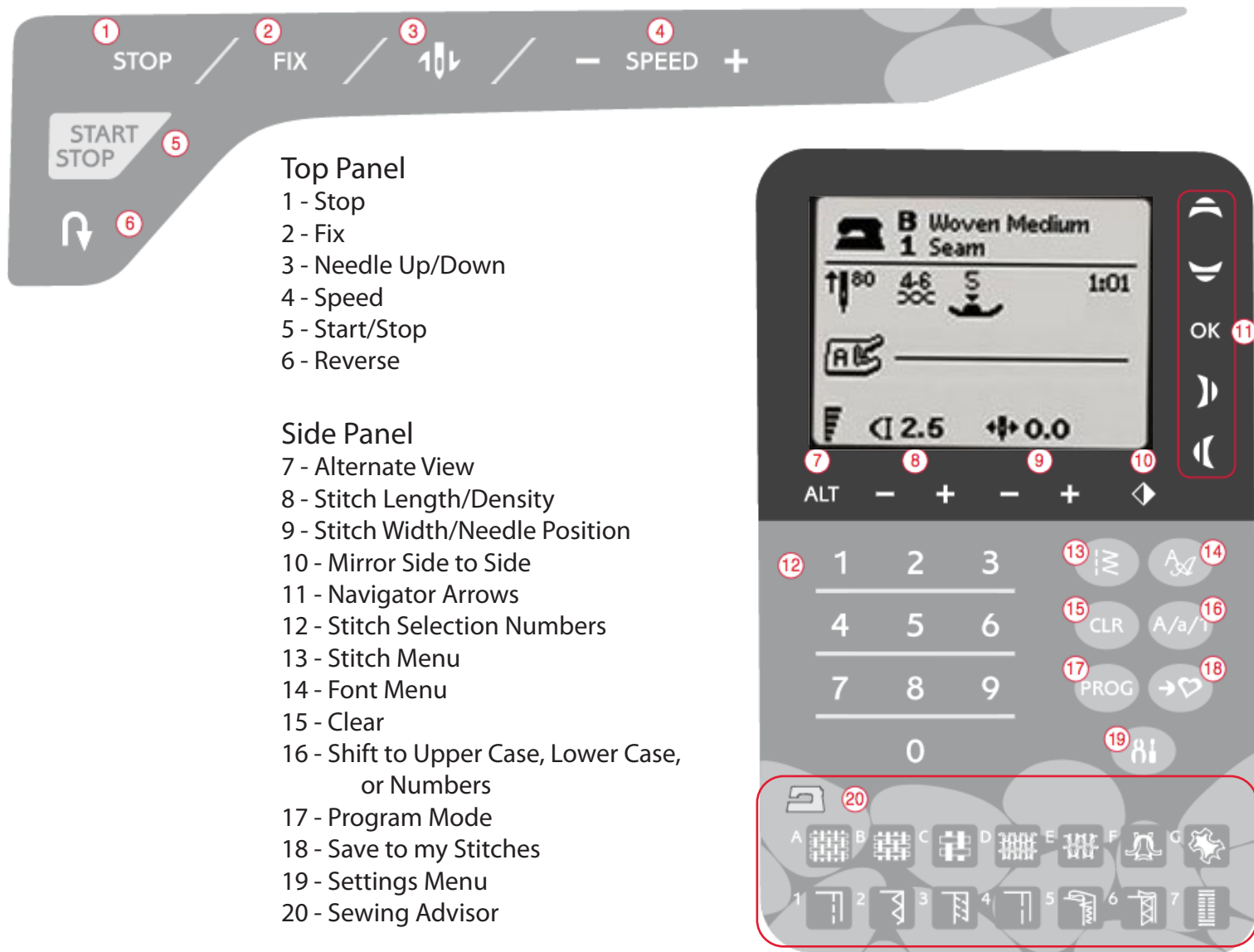

### Top Panel

- 1 - Stop
- 2 - Fix
- 3 - Needle Up/Down
- 4 - Speed
- 5 - Start/Stop
- 6 - Reverse

### Side Panel

- 7 - Alternate View
- 8 - Stitch Length/Density
- 9 - Stitch Width/Needle Position
- 10 - Mirror Side to Side
- 11 - Navigator Arrows
- 12 - Stitch Selection Numbers
- 13 - Stitch Menu
- 14 - Font Menu
- 15 - Clear
- 16 - Shift to Upper Case, Lower Case, or Numbers
- 17 - Program Mode
- 18 - Save to my Stitches
- 19 - Settings Menu
- 20 - Sewing Advisor

## Sewing Advisor

Use these symbols to select the type of fabric you will be using and the sewing technique you wish to use. The Panel will then select the best stitch, stitch length, stitch width, sewing speed, and thread tension.

### Type of Fabric

- A - Woven Light
- B - Woven Medium
- C - Woven Heavy
- D - Stretch Light
- E - Stretch Medium
- F - Stretch Heavy
- G - Leather and Vinyl

### Stitch Selection

- 1 - Seam
- 2 - Overcast
- 3 - Seam/Overcast
- 4 - Baste
- 5 - Blind Hem
- 6 - Hem
- 7 - Buttonhole

# Winding the Bobbin

1. Place an empty bobbin on the bobbin spindle, located at the top right of the machine. The bobbin will only fit on one way, with the logo facing up.

2. Fold the auxiliary spool pin up.

3. Bring the thread over and behind the pre-tension thread guide (A) and down around the tread tension disc (B), then through thread guide (C).

4. Guide the thread through the hole in the bobbin (D) from the inside to the outside.

5. Push the bobbin spindle to the right. Hold the end of the thread firmly, and press the foot control to start winding. When the bobbin is full, it will stop rotating. Push the bobbin spindle back to the left, remove the bobbin, and cut the thread.

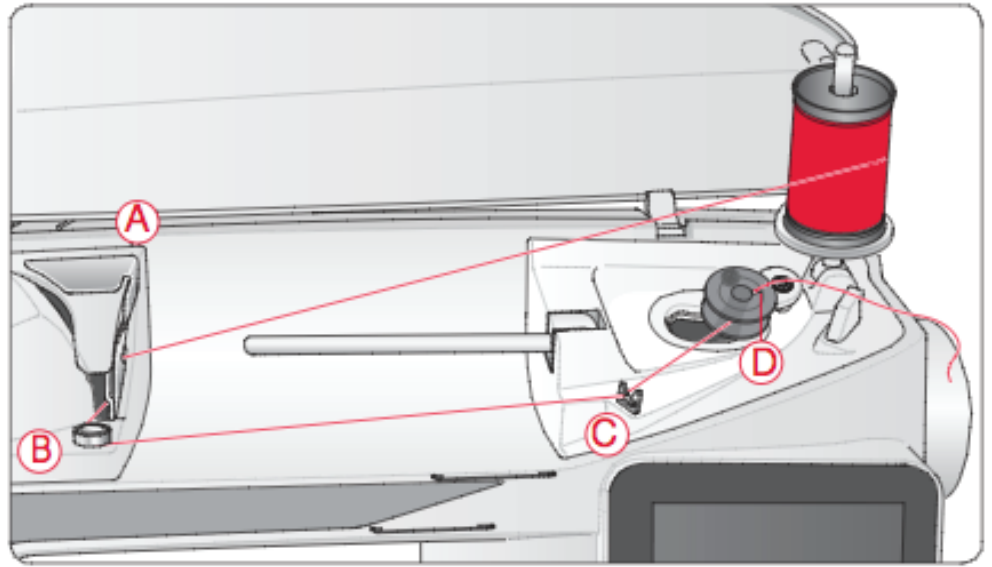

# Threading the Upper Thread

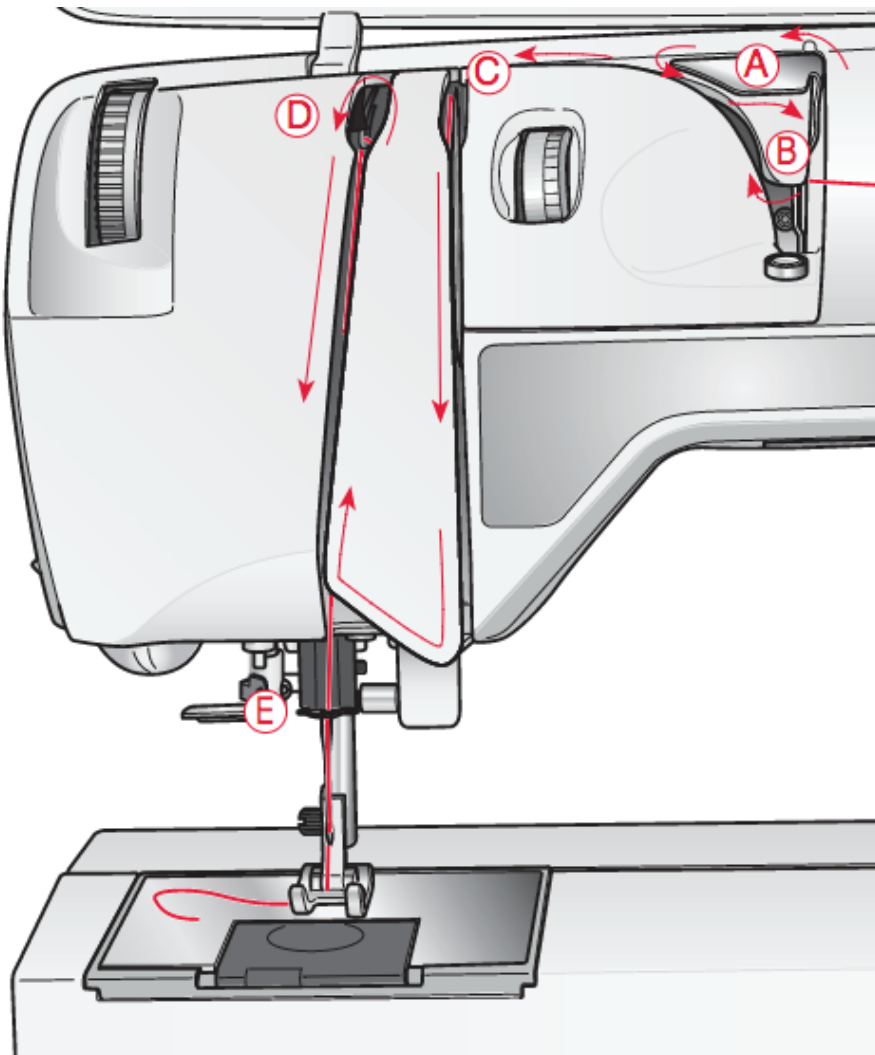

1. Place the thread on the spool pin and secure it with a spool cap.

2. If your spool pin is in the horizontal position, bring the thread over and behind the pre-tension thread guide (A) and under the thread guide (B).

If the spool pin is in a vertical position, bring the thread directly under the thread guide (B).

3. Bring the thread down between the thread tension discs (C).

4. Continue threading following the arrows, and bring the thread from the right into the slot on the take-up lever (D).

5. Take the thread down and behind the last thread guide (E), just above the needle.

6. Thread the needle from front to back.