

# Mini-Net Instructions

© Oncourt Offcourt 2010

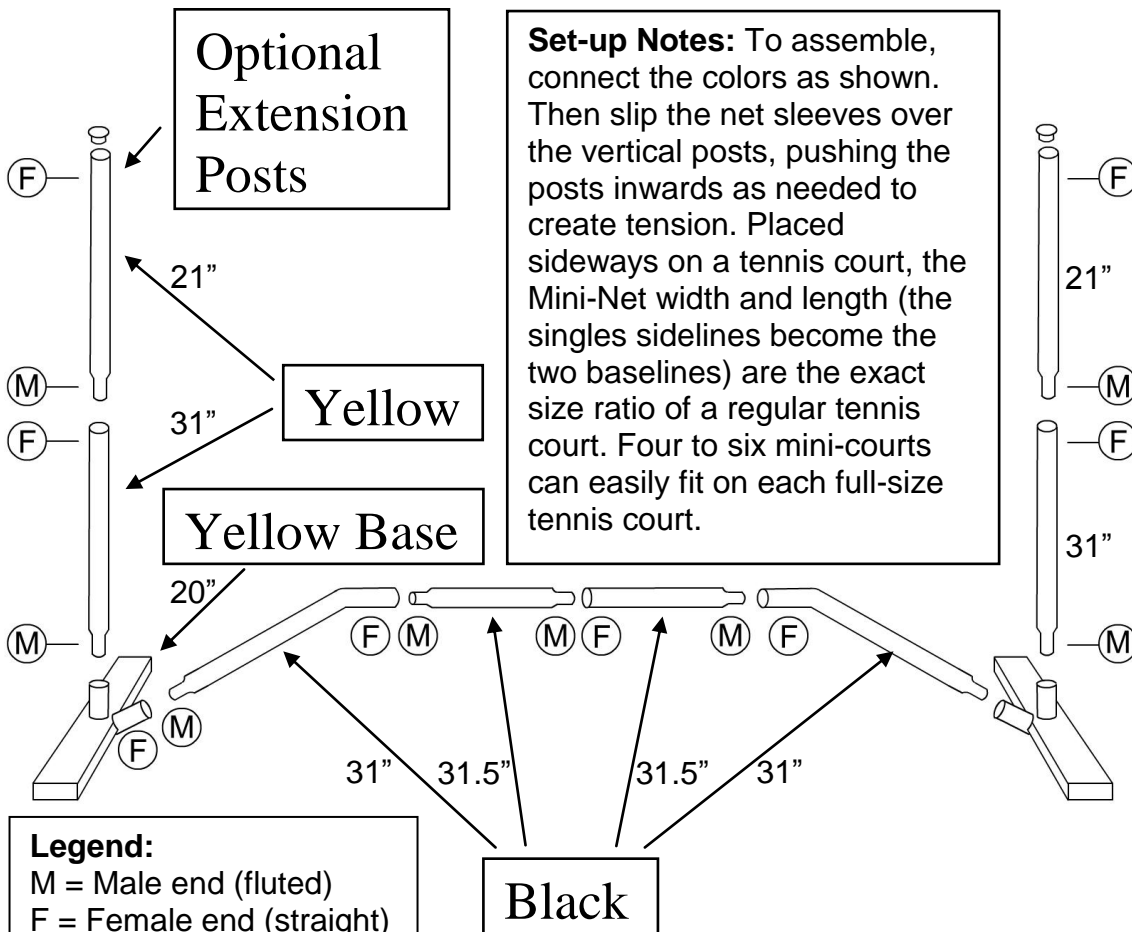

**Set-up Notes:** To assemble, connect the colors as shown. Then slip the net sleeves over the vertical posts, pushing the posts inwards as needed to create tension. Placed sideways on a tennis court, the Mini-Net width and length (the singles sidelines become the two baselines) are the exact size ratio of a regular tennis court. Four to six mini-courts can easily fit on each full-size tennis court.

**Legend:**  
 M = Male end (fluted)  
 F = Female end (straight)  
 Note: Where there are no options, no Male or Female end is notated.

**Additional Notes:** The easy way to repeatedly assemble and disassemble the Mini-Net is to leave the net over the end posts and simply roll the net up into the carry case. The 10-foot wide net is approximately 33 inches high with single posts and 52 inches high with the double posts in use. The Mini-Net adapts easily to all racquet sports, such as tennis and badminton, as well as lead-up volleyball games using foam balls or beach balls.

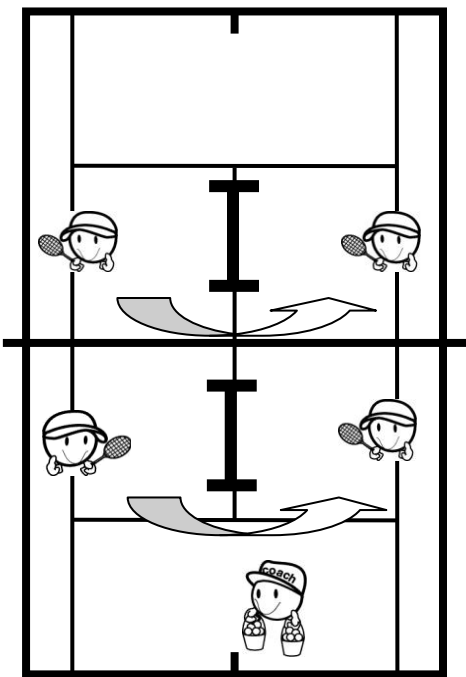

# Mini-Net 3-Step Instructions

**NOTE:**

Have one person at each end hold each net pole. The net will be loose so just hold the net sleeve in place.

**STEP ONE:**

To assemble the frame, connect the colors as shown above. Insert one post into its base but hold the second post separate as shown. Then slip the net sleeves over the vertical yellow posts. The Velcro tension strap and wider headband are at the top.

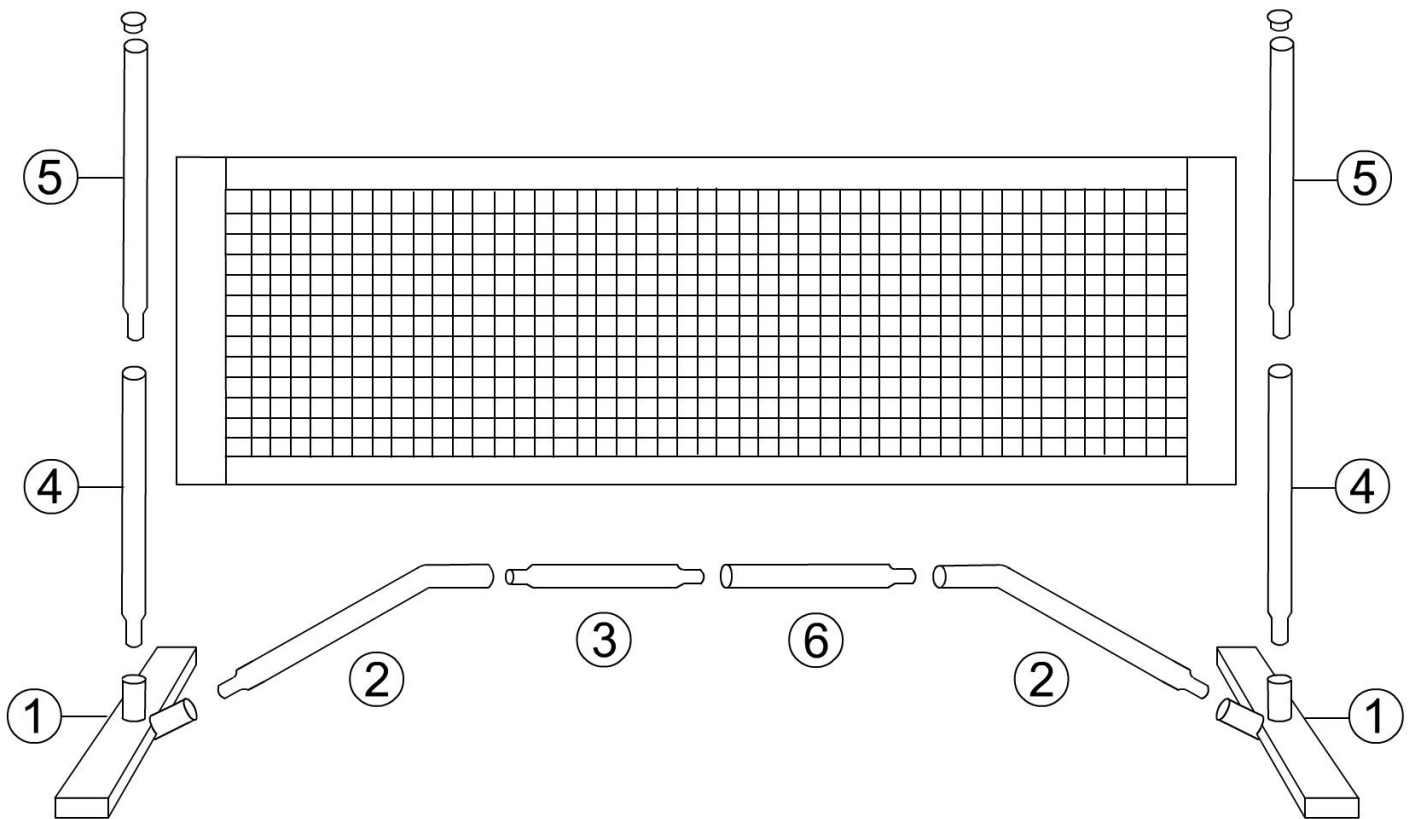

## STEP TWO:

The person holding the pole that is not inserted into the base moves over and inserts the bottom while tilting the pole inwards to keep pressure off the net. In this drawing the right side is fully inserted and the left side is tilted in only at the base.

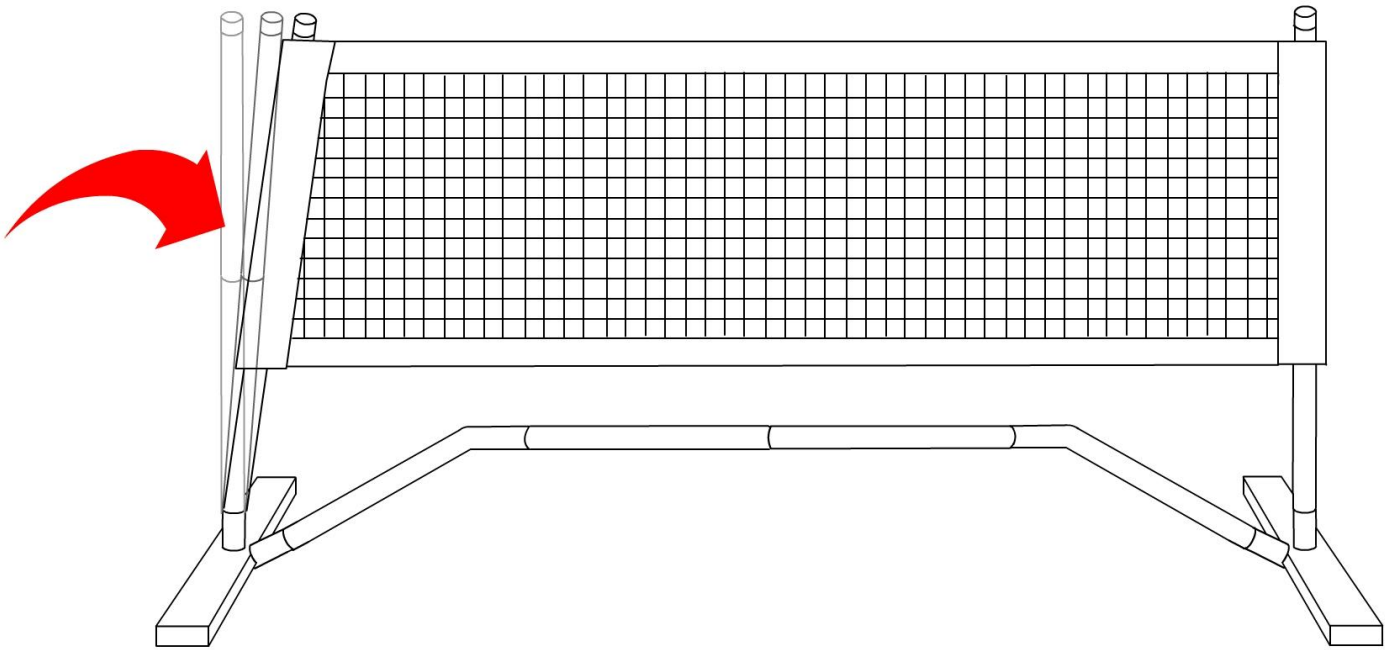

## STEP THREE:

The person holding the pole that is tilted inwards simply keeps the pole in the base while pushing outwards and then slides the pole all the way into the base. Once both posts are in place, you can tighten the Velcro net strap as needed and also adjust the height of the net as well. To most easily adjust the net height, have one person on each side slightly pushing the post inwards by leaning against it and then sliding the net sleeve up or down with the hands.

**NOTE:** The easy way to repeatedly assemble and disassemble the Maxi-Net is to leave the net over the end posts and simply roll the net up into the carry case.

