

COLOrband PiX

USB

User Manual

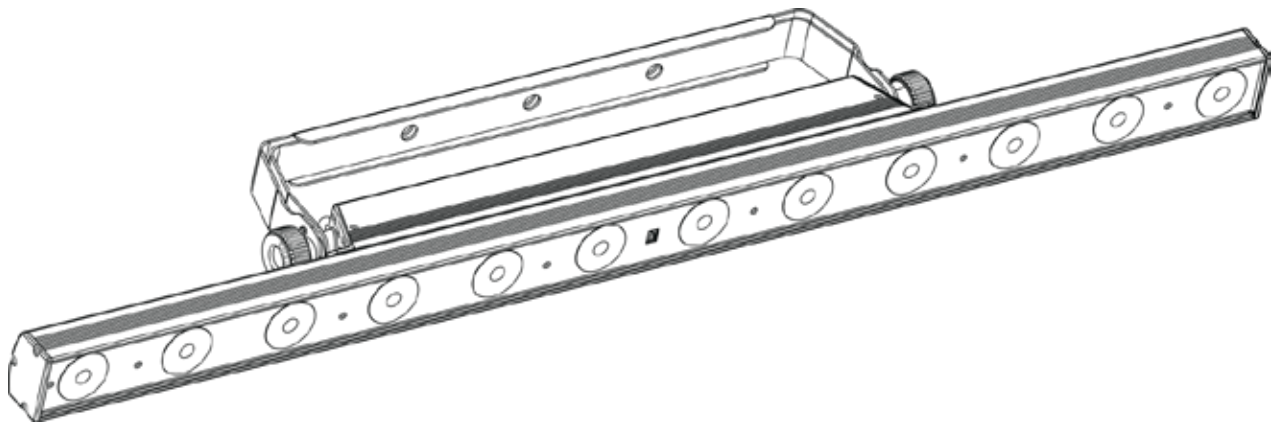

TABLE OF CONTENTS

| | |
|---|----------|
| 1. Before You Begin | 4 |
| What Is Included | 4 |
| Unpacking Instructions | 4 |
| Claims..... | 4 |
| Text Conventions | 4 |
| Symbols | 4 |
| Disclaimer | 4 |
| Product at a Glance | 5 |
| Safety Notes..... | 5 |
| 2. Introduction | 6 |
| Product Overview | 6 |
| Product Dimensions | 6 |
| 3. Setup | 7 |
| AC Power | 7 |
| Fuse Replacement | 7 |
| Power Linking | 7 |
| Mounting | 8 |
| Orientation | 8 |
| Rigging | 8 |
| 4. Operation | 9 |
| Control Panel Operation..... | 9 |
| Menu Map | 9 |
| DMX Personality and Starting Address..... | 9 |
| DMX Linking..... | 10 |
| Configuration (DMX) | 10 |
| D-Fi USB Connectivity | 10 |
| Configuration (D-Fi USB)..... | 10 |
| DMX Channel Assignments and Values | 11 |
| 41CH | 11 |
| Zones for DMX Control (41CH) | 12 |
| 41CH (cont.) | 12 |
| 36CH | 13 |
| Zones for DMX Control (36CH) | 14 |
| 18CH | 14 |
| Zones for DMX Control (18CH) | 14 |
| 12CH | 15 |
| Zones for DMX Control (12CH) | 15 |
| 9-CH | 15 |
| Zones for DMX Control (9-CH) | 15 |
| 8-CH | 16 |
| 7-CH | 17 |
| 6-CH | 18 |
| Zones for DMX Control (6-CH) | 18 |
| 4-CH | 18 |
| 3-CH | 18 |
| Configuration (Standalone) | 19 |
| Automatic Programs | 19 |
| Auto-Program Speed | 19 |
| Sound-Active Mode | 19 |
| Sound Sensitivity | 19 |
| Preset Color Mode..... | 19 |

| | |
|---|-----------|
| Custom Color Mixing | 19 |
| Dimmer Speed..... | 19 |
| IRC-6 Infrared Remote Control | 20 |
| IRC-6 Operation..... | 20 |
| Master/Slave Mode (wired) | 21 |
| Master/Slave Mode (D-Fi USB) | 21 |
| 5. Maintenance | 22 |
| Product Maintenance | 22 |
| 6. Technical Specifications..... | 23 |
| Returns | 24 |
| Contact Us | 25 |

1. BEFORE YOU BEGIN

What Is Included

- COLORband PiX USB
- Hanging Bracket with Mounting Hardware
- Power Cord
- Warranty Card
- Quick Reference Guide

Unpacking Instructions

Carefully unpack the product immediately and check the container to make sure all the parts are in the package and are in good condition.

Claims





If the box or the contents (the product and included accessories) appear damaged from shipping, or show signs of mishandling, notify the carrier immediately, not Chauvet. Failure to report damage to the carrier immediately may invalidate your claim. In addition, keep the box and contents for inspection.

For other issues, such as missing components or parts, damage not related to shipping, or concealed damage, file a claim with Chauvet within 7 days of delivery.

Text Conventions

| Convention | Meaning |
|-----------------|--|
| 1—512 | A range of values |
| 50/60 | A set of values of which only one can be chosen |
| Settings | A menu option not to be modified |
| Menu > Settings | A sequence of menu options to be followed |
| <ENTER> | A key to be pressed on the product's control panel |
| ON | A value to be entered or selected |

Symbols

| Symbol | Meaning |
|---|---|
|  | Electrical warning. Not following these instructions may cause electrical damage to the product, accessories, or the user. |
|  | Critical installation, configuration, or operation information. Not following these instructions may make the product not work, cause damage to the product, or cause harm to the operator. |
|  | Important installation or configuration information. The product may not function correctly if this information is not used. |
|  | Useful information. |

Disclaimer

Chauvet believes that the information contained in this manual is accurate in all respects. However, Chauvet assumes no responsibility and specifically disclaims any and all liability to any party for any loss, damage or disruption caused by any errors or omissions in this document, whether such errors or omissions result from negligence, accident or any other cause. Chauvet reserves the right to revise the content of this document without any obligation to notify any person or company of such revision, however, Chauvet has no obligation to make, and does not commit to make, any such revisions. Download the latest version from www.chauvetlighting.com.

The works of authorship contained in this manual, including, but not limited to, all design, text and images are owned by Chauvet.

© Copyright 2016 Chauvet & Sons, LLC. All rights reserved.

Electronically published by Chauvet in the United States of America.

CHAUVET, the Chauvet logo, COLORband PiX USB, and D-Fi USB are registered trademarks or trademarks of Chauvet & Sons LLC. (d/b/a Chauvet and Chauvet Lighting) in the United States and other countries. Other company and product names and logos referred to herein may be trademarks of their respective companies.

Product at a Glance

| | | | |
|---------------|---|---------------------------|---|
| Use on Dimmer | X | Auto Programs | P |
| Outdoor Use | X | Auto-ranging Power Supply | P |
| Sound-Active | P | Replaceable Fuse | P |
| DMX | P | User-Serviceable | X |
| Master/Slave | P | | |

Safety Notes

Please read the following Safety Notes carefully before working with the product. The Notes include important safety information about installation, usage, and maintenance.



- Always connect the product to a grounded circuit to avoid the risk of electrocution.
- Always disconnect the product from the power source before cleaning or replacing the fuse.
- Avoid direct eye exposure to the light source while the product is on.
- Make sure the power cord is not crimped or damaged.
- Never disconnect the product from power cord by pulling or tugging on the cord.
- If mounting the product overhead, always secure to a fastening device using a safety cable.
- Make sure there are no flammable materials close to the product when operating.
- Do not touch the product's housing when operating because it may be very hot.



- Always make sure that the voltage of the outlet to which you are connecting the product is within the range stated on the decal or rear panel of the product.
- The product is for indoor use only! (IP20) To prevent risk of fire or shock, do not expose the product to rain or moisture.
- Always install the product in a location with adequate ventilation, at least 20 in (50 cm) from adjacent surfaces.
- Be sure that no ventilation slots on the product's housing are blocked.
- Never connect the product to a dimmer.
- Make sure to replace the fuse with another of the same type and rating.
- Never carry the product from the power cord or any moving part. Always use the hanging/mounting bracket.
- The maximum ambient temperature (Ta) is 104 °F (40 °C). Do not operate the product at higher temperatures.
- In the event of a serious operating problem, stop using the product immediately.
- Never try to repair the product. Repairs carried out by unskilled people can lead to damage or malfunction. Please contact the nearest authorized technical assistance center.
- To eliminate unnecessary wear and improve its lifespan, during periods of non-use completely disconnect the product from power via breaker or by unplugging it.



Keep this User Manual for future use. If you sell the product to someone else, be sure that they also receive this document.

2. INTRODUCTION

Product Overview

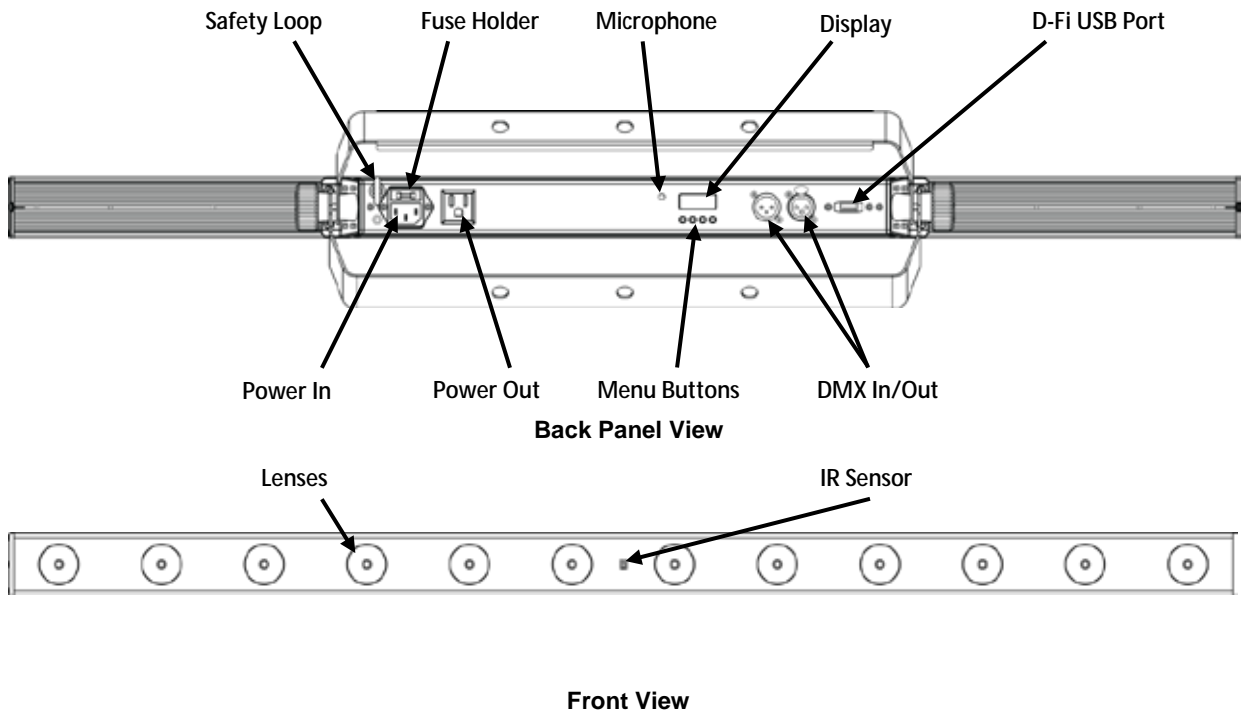

WARNING! DO NOT plug anything other than a D-Fi USB into the USB port. Doing so may cause damage to the product.

Product Dimensions

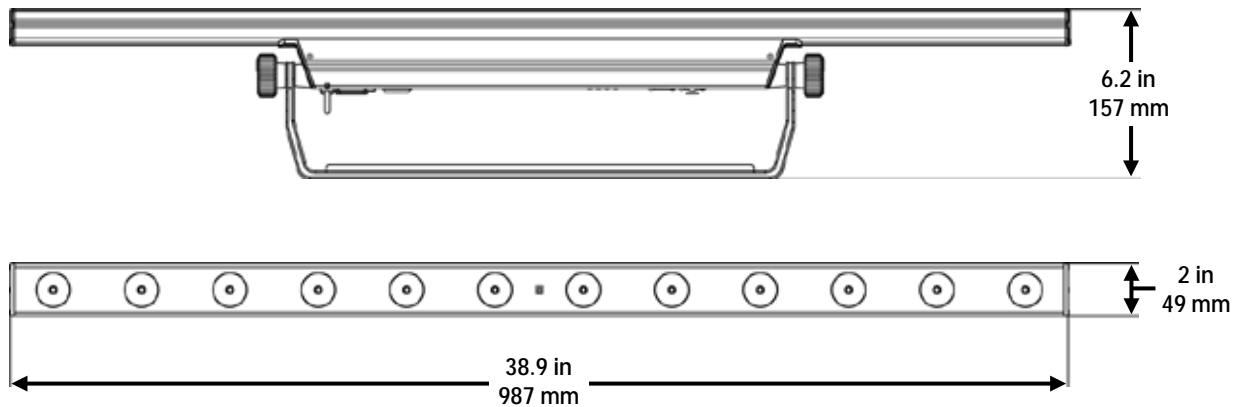

3. SETUP

AC Power

The COLORband PiX USB has an auto-ranging power supply and it can work with an input voltage range of 100 to 240 VAC, 50/60 Hz. To determine the product's power requirements (circuit breaker, power outlet, and wiring), use the current value listed on the label affixed to the product's back panel, or refer to the product's specifications chart. The listed current rating indicates the product's average current draw under normal conditions.



- **Always connect the product to a protected circuit (circuit breaker or fuse). Make sure the product has an appropriate electrical ground to avoid the risk of electrocution or fire.**
- **To eliminate unnecessary wear and improve its lifespan, during periods of non-use completely disconnect the product from power via breaker or by unplugging it.**



Never connect the product to a rheostat (variable resistor) or dimmer circuit, even if the rheostat or dimmer channel serves only as a 0 to 100% switch.

Fuse Replacement

1. Wedge the tip of a flat-head screwdriver into the slot of the fuse holder.
2. Pry the fuse holder out of the housing.
3. Remove the blown fuse from the holder and replace with a fuse of the exact same type and rating.
4. Insert the fuse holder back in place and reconnect power.

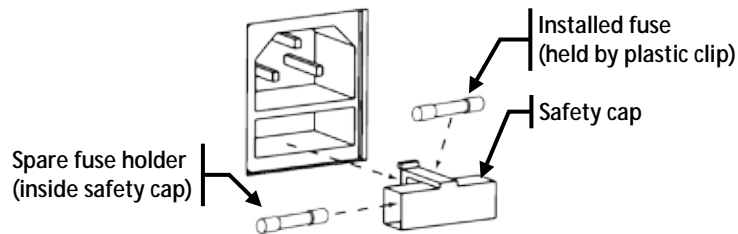

Disconnect the product from the power outlet before replacing the fuse.

Power Linking

The product provides power linking via the Edison outlet located in the back of the product. Please see the diagram below for further explanation.

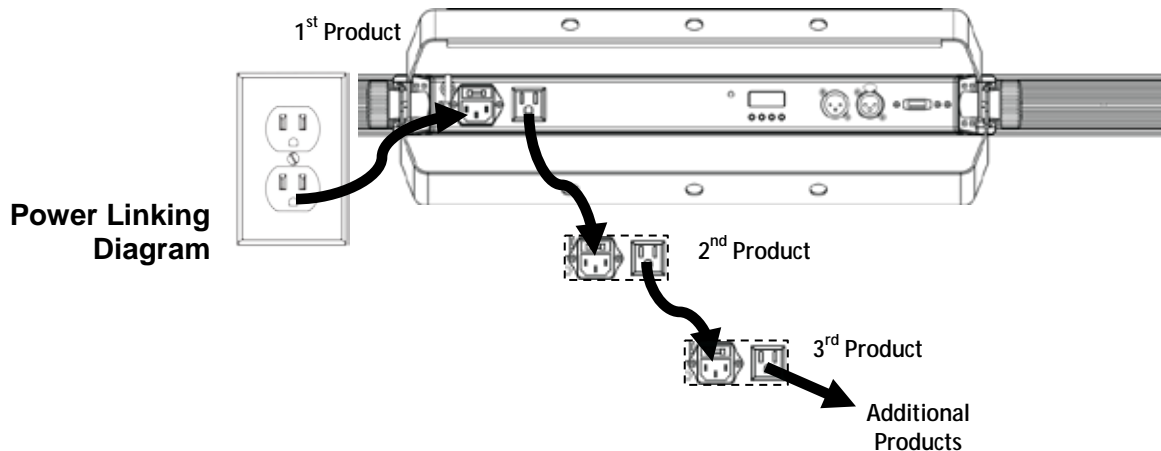

You can power link up to 11 COLORband PiX USB products on 120 VAC or up to 21 COLORband PiX USB products on 230 VAC.



The power linking diagram corresponds to the North American version of the product ONLY! If using the product in other markets, you must consult with the local Chauvet distributor as power linking connectors and requirements may differ in your country or region.

Mounting Before mounting the product, read and follow the safety recommendations indicated in the [Safety Notes](#).

Orientation The COLORband PiX USB may be mounted in any position; however, make sure adequate ventilation is provided around the product.

- Rigging**
- Before deciding on a location for the product, always make sure there is easy access to the product for maintenance and programming purposes.
 - Make sure that the structure onto which you are mounting the product can support the product's weight. See the [Technical Specifications](#) for weight information.
 - When mounting the product overhead, always use a safety cable. Mount the product securely to a rigging point, whether an elevated platform or a truss.
 - When rigging the product onto a truss, use a mounting clamp of appropriate weight capacity.
 - When power linking multiple products, mount the products close enough for power linking cables to reach.
 - The bracket adjustment knobs allow for directional adjustment when aiming the product to the desired angle. Only loosen or tighten the bracket knobs manually. Using tools could damage the knobs.

Mounting Diagram

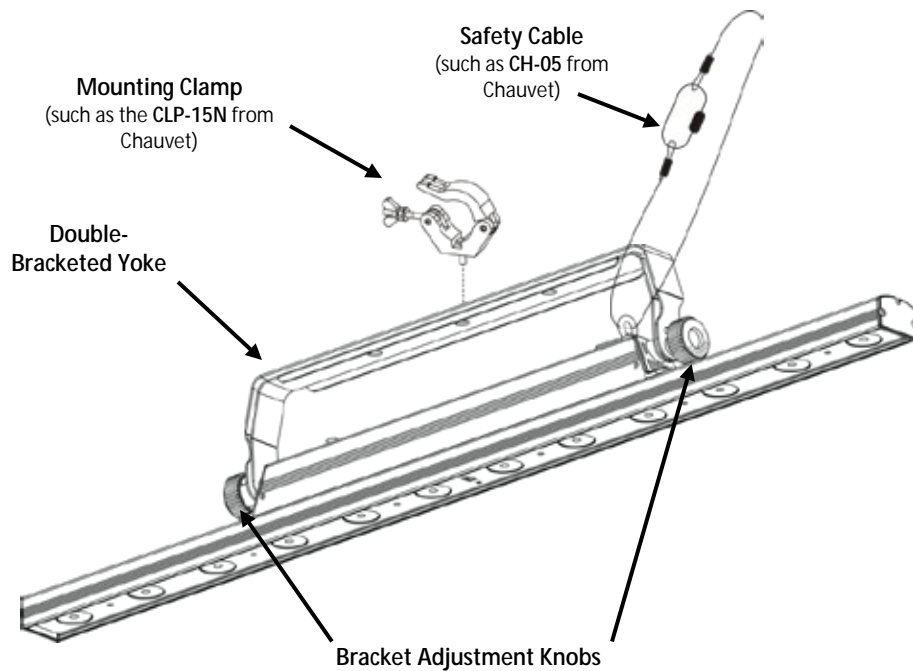

4. OPERATION

Control Panel Operation

To access the control panel functions, use the four buttons located underneath the display. Please refer to the [Product Overview](#) to see the button locations on the control panel.

| Button | Function |
|---------|---|
| <MENU> | Press to find an operation mode or to back out of the current menu option |
| <UP> | Press to scroll up the list of options or to find a higher value |
| <DOWN> | Press to scroll down the list of options or to find a lower value |
| <ENTER> | Press to activate a menu option or a selected value |

Menu Map

| Main Level | Programming Levels | Description |
|-----------------------|--------------------|--|
| 3-CH | d001-512 | 3-channel DMX mode |
| 4-CH | d001-512 | 4-channel DMX mode |
| 6-CH | d001-512 | 6-channel DMX mode |
| 7-CH | d001-512 | 7-channel DMX mode |
| 8-CH | d001-512 | 8-channel DMX mode |
| 9-CH | d001-512 | 9-channel DMX mode |
| 12CH | d001-512 | 12-channel DMX mode |
| 18CH | d001-512 | 18-channel DMX mode |
| 36CH | d001-512 | 36-channel DMX mode |
| 41CH | d001-512 | 41-channel DMX mode |
| C-- | C1-7 | Static colors |
| P-- (automatic) | P1-14 | Automatic programs, 1-14 |
| S-- | S-1-100 | Program speed |
| Snd (sound-active) | Snd | Sound-Active program |
| SenS | u-0-100 | Sound sensitivity setting |
| U-- | r000-255 (red) | Custom static colors Combine red, green, and blue |
| | g000-255 (green) | |
| | b000-255 (blue) | |
| dIM | OFF | Dimmer speed mode, fast to slow, or off |
| | dIM1 | |
| | dIM2 | |
| | dIM3 | |
| SET | On | IR function on or off |
| | OFF | |

DMX Personality and Starting Address

When selecting a starting DMX address, always consider the number of DMX channels the selected DMX mode uses. If you choose a starting address that is too high, you could restrict the access to some of the product's channels.

The COLORband PiX USB uses up to 41 DMX channels in a 41CH DMX mode, which defines the highest configurable address to **472**.

If you are not familiar with the DMX protocol, download the DMX Primer from www.chauvetlighting.com.

To select the starting address, do the following:

1. Press <MENU> repeatedly until **3-CH**, **4-CH**, **6-CH**, **7-CH**, **8-CH**, **9-CH**, **12CH**, **18CH**, **36CH**, or **41CH** shows on the display.
2. Press <ENTER> and **d 1-512** will show on the display.
3. Use <UP> or <DOWN> to select the starting address.
4. Press <ENTER>.

DMX Linking

The COLORband PiX USB works with a DMX controller. Information about DMX is in the CHAUVET DMX Primer, which is available from the Chauvet website http://www.chauvetlighting.com/downloads/DMX_Primer_rev05_WO.pdf.

Configuration (DMX)

Set the product in DMX mode to control with a DMX controller.

1. Connect the product to a suitable power outlet.
2. Connect a DMX cable from the DMX output of the DMX controller to the DMX input socket on the product.

D-Fi USB Connectivity

The COLORband PiX USB is able to become a D-Fi wireless receiver/transmitter with the use of the D-Fi USB from Chauvet DJ. Simply set the product's DMX Personality and DMX Address, set the DIP switch D-Fi receiving/transmitting channel, then plug it into the D-Fi USB port.



WARNING! DO NOT plug anything other than a D-Fi USB into the USB port. Doing so may cause damage to the product.



Once plugged in, the D-Fi USB will take over the product. Wired DMX, manual display control / menu buttons and IRC will be unavailable until you unplug the D-Fi USB. The priority levels are:

1. D-Fi USB
2. Wired DMX
3. IRC-6 Remote Control
4. Manual Digital Display/Menu Buttons

Configuration (D-Fi USB)

1. Set the DMX Personality and DMX address on your product.
2. Use the Chart provided to set **BOTH**:
 - the Channel, and then
 - the Receiving or Transmitting option.

NOTE: DIP Switch 5 is for Transmitting OR Receiving, please choose carefully.

D-Fi USB DIP Switch Channels

| | RECEIVING | | | | TRANSMITTING | | | |
|------------|--------------------------|--------------------------|--------------------------|--------------------------|--------------------------|--------------------------|--------------------------|--------------------------|
| | 1 | 2 | 3 | 4 | 1 | 2 | 3 | 4 |
| Channel 1 | <input type="checkbox"/> | <input type="checkbox"/> | <input type="checkbox"/> | <input type="checkbox"/> | <input type="checkbox"/> | <input type="checkbox"/> | <input type="checkbox"/> | <input type="checkbox"/> |
| Channel 2 | <input type="checkbox"/> | <input type="checkbox"/> | <input type="checkbox"/> | <input type="checkbox"/> | <input type="checkbox"/> | <input type="checkbox"/> | <input type="checkbox"/> | <input type="checkbox"/> |
| Channel 3 | <input type="checkbox"/> | <input type="checkbox"/> | <input type="checkbox"/> | <input type="checkbox"/> | <input type="checkbox"/> | <input type="checkbox"/> | <input type="checkbox"/> | <input type="checkbox"/> |
| Channel 4 | <input type="checkbox"/> | <input type="checkbox"/> | <input type="checkbox"/> | <input type="checkbox"/> | <input type="checkbox"/> | <input type="checkbox"/> | <input type="checkbox"/> | <input type="checkbox"/> |
| Channel 5 | <input type="checkbox"/> | <input type="checkbox"/> | <input type="checkbox"/> | <input type="checkbox"/> | <input type="checkbox"/> | <input type="checkbox"/> | <input type="checkbox"/> | <input type="checkbox"/> |
| Channel 6 | <input type="checkbox"/> | <input type="checkbox"/> | <input type="checkbox"/> | <input type="checkbox"/> | <input type="checkbox"/> | <input type="checkbox"/> | <input type="checkbox"/> | <input type="checkbox"/> |
| Channel 7 | <input type="checkbox"/> | <input type="checkbox"/> | <input type="checkbox"/> | <input type="checkbox"/> | <input type="checkbox"/> | <input type="checkbox"/> | <input type="checkbox"/> | <input type="checkbox"/> |
| Channel 8 | <input type="checkbox"/> | <input type="checkbox"/> | <input type="checkbox"/> | <input type="checkbox"/> | <input type="checkbox"/> | <input type="checkbox"/> | <input type="checkbox"/> | <input type="checkbox"/> |
| Channel 9 | <input type="checkbox"/> | <input type="checkbox"/> | <input type="checkbox"/> | <input type="checkbox"/> | <input type="checkbox"/> | <input type="checkbox"/> | <input type="checkbox"/> | <input type="checkbox"/> |
| Channel 10 | <input type="checkbox"/> | <input type="checkbox"/> | <input type="checkbox"/> | <input type="checkbox"/> | <input type="checkbox"/> | <input type="checkbox"/> | <input type="checkbox"/> | <input type="checkbox"/> |
| Channel 11 | <input type="checkbox"/> | <input type="checkbox"/> | <input type="checkbox"/> | <input type="checkbox"/> | <input type="checkbox"/> | <input type="checkbox"/> | <input type="checkbox"/> | <input type="checkbox"/> |
| Channel 12 | <input type="checkbox"/> | <input type="checkbox"/> | <input type="checkbox"/> | <input type="checkbox"/> | <input type="checkbox"/> | <input type="checkbox"/> | <input type="checkbox"/> | <input type="checkbox"/> |
| Channel 13 | <input type="checkbox"/> | <input type="checkbox"/> | <input type="checkbox"/> | <input type="checkbox"/> | <input type="checkbox"/> | <input type="checkbox"/> | <input type="checkbox"/> | <input type="checkbox"/> |
| Channel 14 | <input type="checkbox"/> | <input type="checkbox"/> | <input type="checkbox"/> | <input type="checkbox"/> | <input type="checkbox"/> | <input type="checkbox"/> | <input type="checkbox"/> | <input type="checkbox"/> |
| Channel 15 | <input type="checkbox"/> | <input type="checkbox"/> | <input type="checkbox"/> | <input type="checkbox"/> | <input type="checkbox"/> | <input type="checkbox"/> | <input type="checkbox"/> | <input type="checkbox"/> |
| Channel 16 | <input type="checkbox"/> | <input type="checkbox"/> | <input type="checkbox"/> | <input type="checkbox"/> | <input type="checkbox"/> | <input type="checkbox"/> | <input type="checkbox"/> | <input type="checkbox"/> |

DMX Channel Assignments and Values

| 41CH | Channel | Function | Value | Percent/Setting | Zone |
|------|---------|----------|-----------|-----------------|------|
| | 1 | Red 1 | 000 ó 255 | 0-100% | 1 |
| | 2 | Green 1 | 000 ó 255 | 0-100% | |
| | 3 | Blue 1 | 000 ó 255 | 0-100% | |
| | 4 | Red 2 | 000 ó 255 | 0-100% | 2 |
| | 5 | Green 2 | 000 ó 255 | 0-100% | |
| | 6 | Blue 2 | 000 ó 255 | 0-100% | |
| | 7 | Red 3 | 000 ó 255 | 0-100% | 3 |
| | 8 | Green 3 | 000 ó 255 | 0-100% | |
| | 9 | Blue 3 | 000 ó 255 | 0-100% | |
| | 10 | Red 4 | 000 ó 255 | 0-100% | 4 |
| | 11 | Green 4 | 000 ó 255 | 0-100% | |
| | 12 | Blue 4 | 000 ó 255 | 0-100% | |
| | 13 | Red 5 | 000 ó 255 | 0-100% | 5 |
| | 14 | Green 5 | 000 ó 255 | 0-100% | |
| | 15 | Blue 5 | 000 ó 255 | 0-100% | |
| | 16 | Red 6 | 000 ó 255 | 0-100% | 6 |
| | 17 | Green 6 | 000 ó 255 | 0-100% | |
| | 18 | Blue 6 | 000 ó 255 | 0-100% | |
| | 19 | Red 7 | 000 ó 255 | 0-100% | 7 |
| | 20 | Green 7 | 000 ó 255 | 0-100% | |
| | 21 | Blue 7 | 000 ó 255 | 0-100% | |
| | 22 | Red 8 | 000 ó 255 | 0-100% | 8 |
| | 23 | Green 8 | 000 ó 255 | 0-100% | |
| | 24 | Blue 8 | 000 ó 255 | 0-100% | |
| | 25 | Red 9 | 000 ó 255 | 0-100% | 9 |
| | 26 | Green 9 | 000 ó 255 | 0-100% | |
| | 27 | Blue 9 | 000 ó 255 | 0-100% | |
| | 28 | Red 10 | 000 ó 255 | 0-100% | 10 |
| | 29 | Green 10 | 000 ó 255 | 0-100% | |
| | 30 | Blue 10 | 000 ó 255 | 0-100% | |
| | 31 | Red 11 | 000 ó 255 | 0-100% | 11 |
| | 32 | Green 11 | 000 ó 255 | 0-100% | |
| | 33 | Blue 11 | 000 ó 255 | 0-100% | |
| | 34 | Red 12 | 000 ó 255 | 0-100% | 12 |
| | 35 | Green 12 | 000 ó 255 | 0-100% | |
| | 36 | Blue 12 | 000 ó 255 | 0-100% | |

Zones for DMX Control (41CH)

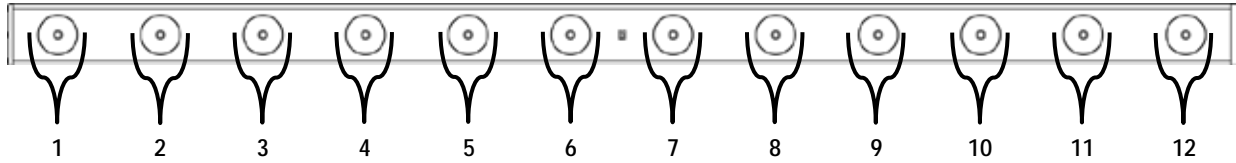

| 41CH (cont.) | Channel | Function | Value | Percent/Setting |
|--------------|--------------------------|---|--|------------------------------------|
| 37 | | Color Macros (Overrides Ch. 1–18) | 000 ó 014 | No function |
| | | | 015 ó 255 | Color macros |
| 38 | | Strobe (when CH39 is 000–031) | 000 ó 015 | No function |
| | | | 016 ó 255 | Strobe, slow to fast |
| 38 | | Speed (when CH39 is 032–226) | 000 ó 255 | Slow to fast |
| | | | Sound Sensitivity (when CH39 is 227–255) | 000 ó 010 |
| | | | | 011 ó 255 |
| | | | 39 | Auto Programs |
| 032 ó 063 | Pulse effect 0–100% | | | |
| 064 ó 095 | Pulse effect 100%–0 | | | |
| 096 ó 114 | Pulse effect 100%–0–100% | | | |
| 115 ó 122 | Auto program 1 | | | |
| 123 ó 130 | Auto program 2 | | | |
| 131 ó 138 | Auto program 3 | | | |
| 139 ó 146 | Auto program 4 | | | |
| 147 ó 154 | Auto program 5 | | | |
| 155 ó 162 | Auto program 6 | | | |
| 163 ó 170 | Auto program 7 | | | |
| 171 ó 178 | Auto program 8 | | | |
| 179 ó 186 | Auto program 9 | | | |
| 187 ó 194 | Auto program 10 | | | |
| 195 ó 202 | Auto program 11 | | | |
| 203 ó 210 | Auto program 12 | | | |
| 211 ó 218 | Auto program 13 | | | |
| 219 ó 226 | Auto program 14 | | | |
| 227 ó 255 | Sound-Active program | | | |
| 40 | | Dimmer | 000 ó 255 | 0–100% |
| 41 | | Dimmer Speed | 000 ó 051 | Default dimmer speed set from menu |
| | | | 052 ó 101 | Dimmer speed mode off |
| | | | 102 ó 152 | Dimmer speed mode 1 (fast speed) |
| | | | 153 ó 203 | Dimmer speed mode 2 (medium speed) |
| | | | 204 ó 255 | Dimmer speed mode 3 (slow speed) |

| 36CH | Channel | Function | Value | Percent/Setting | Zone |
|-------------|----------------|-----------------|--------------|------------------------|-------------|
| | 1 | Red 1 | 000 ó 255 | 0-100% | 1 |
| | 2 | Green 1 | 000 ó 255 | 0-100% | |
| | 3 | Blue 1 | 000 ó 255 | 0-100% | |
| | 4 | Red 2 | 000 ó 255 | 0-100% | 2 |
| | 5 | Green 2 | 000 ó 255 | 0-100% | |
| | 6 | Blue 2 | 000 ó 255 | 0-100% | |
| | 7 | Red 3 | 000 ó 255 | 0-100% | 3 |
| | 8 | Green 3 | 000 ó 255 | 0-100% | |
| | 9 | Blue 3 | 000 ó 255 | 0-100% | |
| | 10 | Red 4 | 000 ó 255 | 0-100% | 4 |
| | 11 | Green 4 | 000 ó 255 | 0-100% | |
| | 12 | Blue 4 | 000 ó 255 | 0-100% | |
| | 13 | Red 5 | 000 ó 255 | 0-100% | 5 |
| | 14 | Green 5 | 000 ó 255 | 0-100% | |
| | 15 | Blue 5 | 000 ó 255 | 0-100% | |
| | 16 | Red 6 | 000 ó 255 | 0-100% | 6 |
| | 17 | Green 6 | 000 ó 255 | 0-100% | |
| | 18 | Blue 6 | 000 ó 255 | 0-100% | |
| | 19 | Red 7 | 000 ó 255 | 0-100% | 7 |
| | 20 | Green 7 | 000 ó 255 | 0-100% | |
| | 21 | Blue 7 | 000 ó 255 | 0-100% | |
| | 22 | Red 8 | 000 ó 255 | 0-100% | 8 |
| | 23 | Green 8 | 000 ó 255 | 0-100% | |
| | 24 | Blue 8 | 000 ó 255 | 0-100% | |
| | 25 | Red 9 | 000 ó 255 | 0-100% | 9 |
| | 26 | Green 9 | 000 ó 255 | 0-100% | |
| | 27 | Blue 9 | 000 ó 255 | 0-100% | |
| | 28 | Red 10 | 000 ó 255 | 0-100% | 10 |
| | 29 | Green 10 | 000 ó 255 | 0-100% | |
| | 30 | Blue 10 | 000 ó 255 | 0-100% | |
| | 31 | Red 11 | 000 ó 255 | 0-100% | 11 |
| | 32 | Green 11 | 000 ó 255 | 0-100% | |
| | 33 | Blue 11 | 000 ó 255 | 0-100% | |
| | 34 | Red 12 | 000 ó 255 | 0-100% | 12 |
| | 35 | Green 12 | 000 ó 255 | 0-100% | |
| | 36 | Blue 12 | 000 ó 255 | 0-100% | |

Zones for DMX Control (36CH)

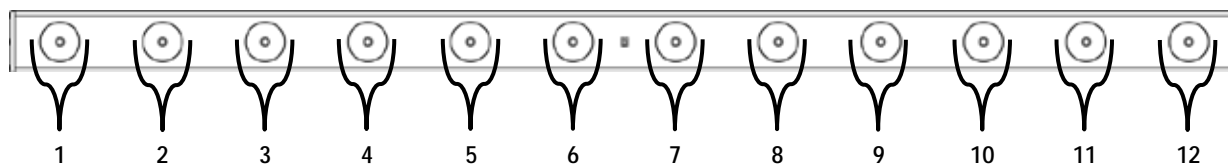

| 18CH | Channel | Function | Value | Percent/Setting | Zone |
|------|---------|----------|-----------|-----------------|------|
| | 1 | Red 1 | 000 ◊ 255 | 0-100% | 1 |
| | 2 | Green 1 | 000 ◊ 255 | 0-100% | |
| | 3 | Blue 1 | 000 ◊ 255 | 0-100% | |
| | 4 | Red 2 | 000 ◊ 255 | 0-100% | 2 |
| | 5 | Green 2 | 000 ◊ 255 | 0-100% | |
| | 6 | Blue 2 | 000 ◊ 255 | 0-100% | |
| | 7 | Red 3 | 000 ◊ 255 | 0-100% | 3 |
| | 8 | Green 3 | 000 ◊ 255 | 0-100% | |
| | 9 | Blue 3 | 000 ◊ 255 | 0-100% | |
| | 10 | Red 4 | 000 ◊ 255 | 0-100% | 4 |
| | 11 | Green 4 | 000 ◊ 255 | 0-100% | |
| | 12 | Blue 4 | 000 ◊ 255 | 0-100% | |
| | 13 | Red 5 | 000 ◊ 255 | 0-100% | 5 |
| | 14 | Green 5 | 000 ◊ 255 | 0-100% | |
| | 15 | Blue 5 | 000 ◊ 255 | 0-100% | |
| | 16 | Red 6 | 000 ◊ 255 | 0-100% | 6 |
| | 17 | Green 6 | 000 ◊ 255 | 0-100% | |
| | 18 | Blue 6 | 000 ◊ 255 | 0-100% | |

Zones for DMX Control (18CH)

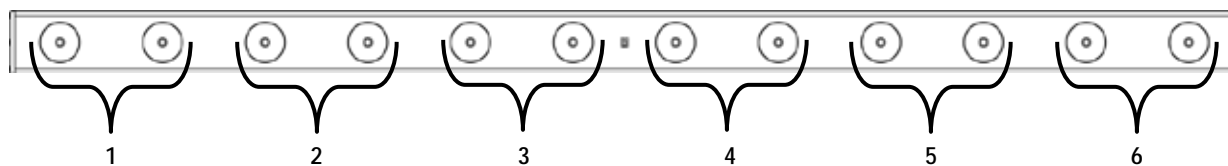

| 12CH | Channel | Function | Value | Percent/Setting | Zone |
|------|---------|----------|-----------|-----------------|------|
| | 1 | Red 1 | 000 ó 255 | 0-100% | 1 |
| | 2 | Green 1 | 000 ó 255 | 0-100% | |
| | 3 | Blue 1 | 000 ó 255 | 0-100% | |
| | 4 | Red 2 | 000 ó 255 | 0-100% | 2 |
| | 5 | Green 2 | 000 ó 255 | 0-100% | |
| | 6 | Blue 2 | 000 ó 255 | 0-100% | |
| | 7 | Red 3 | 000 ó 255 | 0-100% | 3 |
| | 8 | Green 3 | 000 ó 255 | 0-100% | |
| | 9 | Blue 3 | 000 ó 255 | 0-100% | |
| | 10 | Red 4 | 000 ó 255 | 0-100% | 4 |
| | 11 | Green 4 | 000 ó 255 | 0-100% | |
| | 12 | Blue 4 | 000 ó 255 | 0-100% | |

Zones for DMX Control (12CH)

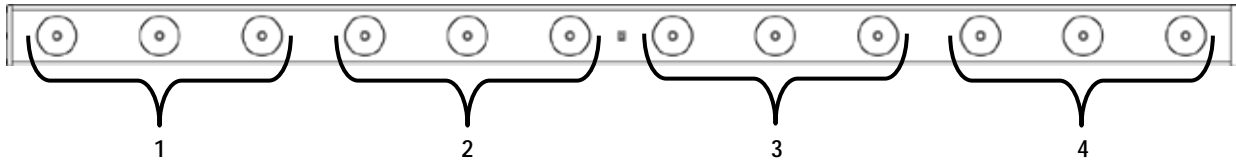

| 9-CH | Channel | Function | Value | Percent/Setting | Zone |
|------|---------|----------|-----------|-----------------|------|
| | 1 | Red 1 | 000 ó 255 | 0-100% | 1 |
| | 2 | Green 1 | 000 ó 255 | 0-100% | |
| | 3 | Blue 1 | 000 ó 255 | 0-100% | |
| | 4 | Red 2 | 000 ó 255 | 0-100% | 2 |
| | 5 | Green 2 | 000 ó 255 | 0-100% | |
| | 6 | Blue 2 | 000 ó 255 | 0-100% | |
| | 7 | Red 3 | 000 ó 255 | 0-100% | 3 |
| | 8 | Green 3 | 000 ó 255 | 0-100% | |
| | 9 | Blue 3 | 000 ó 255 | 0-100% | |

Zones for DMX Control (9-CH)

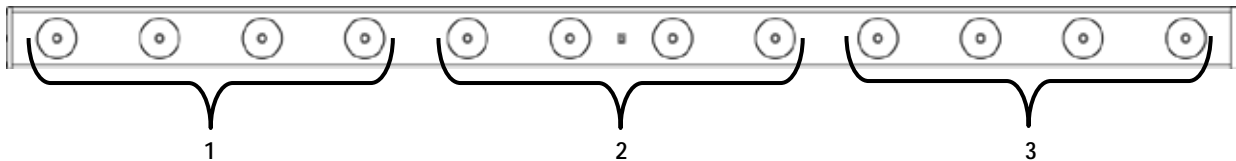

| 8-CH | Channel | Function | Value | Percent/Setting | |
|------|-----------|--|-----------|-------------------------------------|----------------------------|
| | 1 | Red | 000 ó 255 | 0–100% | |
| | 2 | Green | 000 ó 255 | 0–100% | |
| | 3 | Blue | 000 ó 255 | 0–100% | |
| | 4 | Color Macros (Overrides Ch. 1–3) | 000 ó 015 | No function | |
| | | | 016 ó 255 | Color macros | |
| | 5 | Strobe (when CH6 is 000–031) | 000 ó 015 | No function | |
| | | | 016 ó 255 | Strobe, slow to fast | |
| | | Speed (when CH6 is 032–226) | 000 ó 255 | Slow to fast | |
| | | Sound Sensitivity (when CH6 is 227–255) | 000 ó 010 | Off | |
| | | | 011 ó 255 | Control the sound sensitivity level | |
| | 6 | Auto Programs | 000 ó 031 | No function | |
| | | | 032 ó 063 | Pulse effect 0–100% | When Ch. 1–3 are active |
| | | | 064 ó 095 | Pulse effect 100%–0 | |
| | | | 096 ó 114 | Pulse effect 100%–0–100% | |
| | | | 115 ó 122 | Auto program 1 | |
| | | | 123 ó 130 | Auto program 2 | |
| | | | 131 ó 138 | Auto program 3 | |
| | | | 139 ó 146 | Auto program 4 | |
| | | | 147 ó 154 | Auto program 5 | |
| | | | 155 ó 162 | Auto program 6 | |
| | | | 163 ó 170 | Auto program 7 | |
| | | | 171 ó 178 | Auto program 8 | |
| | | | 179 ó 186 | Auto program 9 | |
| | | | 187 ó 194 | Auto program 10 | |
| | | | 195 ó 202 | Auto program 11 | |
| | | | 203 ó 210 | Auto program 12 | |
| | 211 ó 218 | Auto program 13 | | | |
| | 219 ó 226 | Auto program 14 | | | |
| | 227 ó 255 | Sound-Active program | | | |
| | 7 | Dimmer | 000 ó 255 | 0–100% | |
| | 8 | Dimmer Speed | 000 ó 051 | Default dimmer speed set from menu | |
| | | | 052 ó 101 | Dimmer speed mode off | |
| | | | 102 ó 152 | Dimmer speed mode 1 (fast speed) | |
| | | | 153 ó 203 | Dimmer speed mode 2 (medium speed) | |
| | | | 204 ó 255 | Dimmer speed mode 3 (slow speed) | |

| 7-CH | Channel | Function | Value | Percent/Setting | |
|-------------|----------------|--|--------------|--------------------------|----------------------------|
| | 1 | Red | 000 ó 255 | 0–100% | |
| | 2 | Green | 000 ó 255 | 0–100% | |
| | 3 | Blue | 000 ó 255 | 0–100% | |
| | 4 | Color Macros (Overrides Ch. 1–3) | 000 ó 015 | No function | |
| | | | 016 ó 255 | Color macros | |
| | 5 | Strobe (when CH6 is 000–031) | 000 ó 015 | No function | |
| | | | 016 ó 255 | Strobe, slow to fast | |
| | | Speed (when CH6 is 032–223) | 000 ó 255 | Slow to fast | |
| | 6 | Auto Programs | 000 ó 031 | No function | |
| | | | 032 ó 063 | Pulse effect 0–100% | When Ch. 1–3 are active |
| | | | 064 ó 095 | Pulse effect 100%–0 | |
| | | | 096 ó 114 | Pulse effect 100%–0–100% | |
| | | | 115 ó 127 | Chase program | |
| | | | 128 ó 159 | Auto fade transition | |
| | | | 160 ó 191 | 3-color program (snap) | |
| | | | 192 ó 223 | 7-color program (snap) | |
| | 224 ó 255 | Sound-Active program | | | |
| | 7 | Dimmer | 000 ó 255 | 0–100% | |

| 6-CH | Channel | Function | Value | Percent/Setting | Zone |
|------|---------|----------|-----------|-----------------|------|
| | 1 | Red 1 | 000 ◊ 255 | 0-100% | 1 |
| | 2 | Green 1 | 000 ◊ 255 | 0-100% | |
| | 3 | Blue 1 | 000 ◊ 255 | 0-100% | |
| | 4 | Red 2 | 000 ◊ 255 | 0-100% | 2 |
| | 5 | Green 2 | 000 ◊ 255 | 0-100% | |
| | 6 | Blue 2 | 000 ◊ 255 | 0-100% | |

Zones for DMX Control (6-CH)

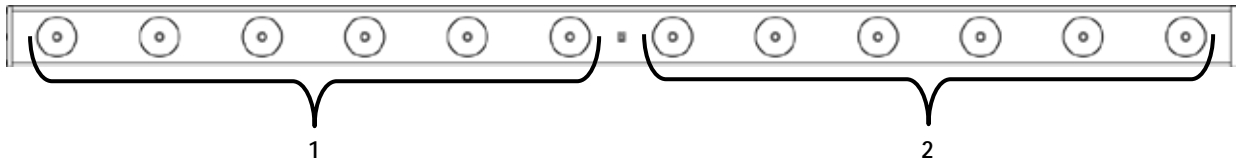

| 4-CH | Channel | Function | Value | Percent/Setting |
|------|---------|----------|-----------|-----------------|
| | 1 | Red | 000 ◊ 255 | 0-100% |
| | 2 | Green | 000 ◊ 255 | 0-100% |
| | 3 | Blue | 000 ◊ 255 | 0-100% |
| | 4 | Dimmer | 000 ◊ 255 | 0-100% |

| 3-CH | Channel | Function | Value | Percent/Setting |
|------|---------|----------|-----------|-----------------|
| | 1 | Red | 000 ◊ 255 | 0-100% |
| | 2 | Green | 000 ◊ 255 | 0-100% |
| | 3 | Blue | 000 ◊ 255 | 0-100% |

Configuration (Standalone)

Set the product in one of the standalone modes to control without a DMX controller.
Connect the product to a suitable power outlet.



Never connect a product that is operating in any standalone mode to a DMX string connected to a DMX controller. Products in standalone mode may transmit DMX signals that could interfere with the DMX signals from the controller.

Automatic Programs

To run the COLORband PiX USB in automatic mode, follow the instructions below:

1. Press **<MENU>** repeatedly until **P--** shows on the display.
2. Press **<ENTER>**.
3. Use **<UP>** and **<DOWN>** to select an auto program (**P1–14**).
4. Press **<ENTER>**.

Auto-Program Speed

To change the auto-program speed on the COLORband PiX USB, do the following:

1. Press **<MENU>** repeatedly until **S--** shows on the display.
2. Use **<UP>** and **<DOWN>** to increase or decrease the program speed (**S--1–100**).
3. Press **<ENTER>**. The product will return to the last selected mode.

Sound-Active Mode

To run the COLORband PiX USB in sound-active mode, do the following:

1. Press **<MENU>** repeatedly until **Snd** shows on the display.
2. Press **<ENTER>**.



The product will only respond to low frequencies of music (bass and drums).

Sound Sensitivity

To change the sound sensitivity on the COLORband PiX USB, follow the instructions below:

1. Press **<MENU>** repeatedly until **SenS** shows on the display.
2. Use **<UP>** and **<DOWN>** to increase or decrease the sound sensitivity (**u--0–100**).
3. Press **<ENTER>**. The product will return to the last selected mode.

Preset Color Mode

To run the COLORband PiX USB in preset color mode, follow the instructions below:

1. Press **<MENU>** repeatedly until **C--** shows on the display.
2. Press **<ENTER>**.
3. Use **<UP>** and **<DOWN>** to select a static color (**C1–7**).
4. Press **<ENTER>**.

Custom Color Mixing

To custom mix a static color, follow the instructions below:

1. Press **<MENU>** repeatedly until **U--** shows on the display.
2. Press **<ENTER>** and one of the following will show on the display:
 - **r__** (red)
 - **g__** (green)
 - **b__** (blue)
3. Press **<ENTER>** to cycle through the color settings.
4. When the desired color shows on the display, use **<UP>** or **<DOWN>** to increase or decrease the color value.
5. Repeat steps 3 and 4 until the product outputs as desired.

Dimmer Speed

To change dimmer speed on the COLORband PiX USB, do the following:

1. Press **<MENU>** repeatedly until **dIM** shows on the display.
2. Press **<ENTER>**.
3. Use **<UP>** and **<DOWN>** to select:
 - **dIM1** (fast)
 - **dIM2** (medium)
 - **dIM3** (slow)
 - or
 - **OFF**.
4. Press **<ENTER>**.

IRC-6 Infrared Remote Control

The COLORband PiX USB is compatible with the IRC-6 infrared remote control from Chauvet. To activate IR mode, follow the instructions below:

1. Press **<MENU>** repeatedly until **SET** shows on the display.
2. Press **<ENTER>** to accept.
3. Press **<UP>** or **<DOWN>** to select **On** or **OFF**.
4. Press **<ENTER>**.

IRC-6 Operation



Automatic Mode

Automatic mode will enable you to run the automatic programs on the product.

To turn on Automatic mode:

1. Press **<AUTO>** on the IRC-6.
2. Press **<+>** or **<->** to choose between the different auto programs.

To adjust the speed of the automatic program:

1. Press **<SPEED>** on the IRC-6.
2. Press **<+>** or **<->** to increase or decrease the speed of the program.

Sound-Active Mode

Sound-Active mode will enable the product to respond to the music.

To turn on Sound-Active mode:

Press **<SOUND>** on the IRC-6.

To adjust sound sensitivity in Sound-Active mode:

1. Press **<SENSITIVITY>** on the IRC-6.
2. Press **<+>** or **<->** to increase or decrease the sound sensitivity.

Manual Color Control

To choose a specific color with the IRC-6:

1. Press **<MANUAL>** on the IRC-6.
2. Press any number between **<0>**~**<9>** to choose your color.

To manually control the RGB percentage:

1. Press **<MANUAL>** on the IRC-6.
2. Press **<R>** (red), **<G>** (green), or **** (blue) to choose your color.
3. Press **<+>** or **<->** to increase or decrease the percentage of each color.

Miscellaneous Operation

To adjust the total output level:

1. Press **<%>** on the IRC-6.
2. Press **<+>** or **<->** to increase or decrease the output level.

To adjust the strobe rate of the program:

1. Press **<STROBE>** on the IRC-6.
2. Press **<+>** or **<->** to increase or decrease the strobe rate.
3. Press **<STROBE>** again to turn off the strobe.

To select only fading programs:

1. Press **<FADE>** on the IRC-6.
2. Press **<+>** or **<->** to select **P11** or **P13**.

To black out the lights:

1. Press **<BLACK OUT>** on the IRC-6.

This will turn off all the lights until the button is pressed again.

NOTE: The IRC-6 will not respond to any inputs when Black Out is activated. If the remote does not respond when a button is pressed, try pressing **<BLACK OUT>**. You may have inadvertently activated Black Out.

Master/Slave Mode (wired)

The Master/Slave mode allows a single COLORband PiX USB product (the “master”) to control the actions of one or more COLORband PiX USB products (the “slaves”) without the need of a DMX controller. The master product will be set to operate in either Stand-Alone mode or with the IRC-6, while the slave products will be set to operate in Slave mode. Once set and connected, the slave products will operate in unison with the master product.

Configure the products as indicated below.

Slave products:

1. Press **<MENU>** repeatedly until **36CH** shows on the display.
2. Press **<ENTER>** to accept.
3. Set the DMX address to **d 1**.
4. Connect the DMX input of the first slave product to the DMX output of the master product.
5. Connect the DMX input of the subsequent slave products to the DMX output of the previous slave product.
6. Finish setting and connecting all the slave products.

Master product:

1. Set the master product to operate in either Stand-Alone mode or with the IRC-6.
2. Make the master product the first product in the DMX daisy chain.



- **Configure all the slave products before connecting the master to the daisy chain.**
- **Never connect a DMX controller to a DMX string configured for Master/Slave operation because the controller may interfere with the signals from the master.**
- **Do not connect more than 31 slaves to the master.**
- **A COLORband PiX USB must be the master product when in Master/Slave configuration with COLORband PiX products.**

Master/Slave Mode (D-Fi USB)

The D-Fi USB allows a single COLORband PiX USB product (the “master”) to control the actions of one or more COLORband PiX USB products (the “slaves”) without the need of a DMX controller or DMX cables. The master (transmitter) product will be set to operate in either Stand-Alone mode or with the IRC-6, while the slave (receiver) products will be set to operate in Slave mode. Once set and connected, the slave products will operate in unison with the master product.

Configure the products as indicated below.

Slave products:

1. Press **<MENU>** repeatedly until **36CH** shows on the display.
2. Press **<ENTER>** to accept.
3. Set the DMX address to **d 1**.
4. Set the D-Fi USB to receive on a specific channel, 1–16.
5. Plug in the D-Fi USB.
6. Finish setting and connecting all the slave products.

Master product:

1. Set the master product to operate in either Stand-Alone mode or with the IRC-6.
2. Set the D-Fi USB to transmit on the D-Fi channel the slaves are receiving on.
3. Plug in the D-Fi USB.



- **All products must be set to the same DMX personality, DMX address, and D-Fi channel.**
- **Configure all the slave products before configuring the master to transmit.**
- **Never connect a DMX controller to a D-Fi channel configured for Master/Slave operation because the controller may interfere with the signals from the master.**
- **A COLORband PiX USB must be the master product when in Master/Slave configuration with COLORband PiX products.**

5. MAINTENANCE

Product Maintenance

Dust build-up reduces light output performance and can cause overheating. This can lead to reduction of the light source's life and/or mechanical wear. To maintain optimum performance and minimize wear, clean your lighting products at least twice a month. However, be aware that usage and environmental conditions could be contributing factors to increase the cleaning frequency.

To clean the product, follow the instructions below:

1. Unplug the product from power.
2. Wait until the product is at room temperature.
3. Use a vacuum (or dry compressed air) and a soft brush to remove dust collected on the external surface/vents.
4. Clean all transparent surfaces with a mild soap solution, ammonia-free glass cleaner, or isopropyl alcohol.
5. Apply the solution directly to a soft, lint free cotton cloth or a lens cleaning tissue.
6. Softly drag any dirt or grime to the outside of the transparent surface.
7. Gently polish the transparent surfaces until they are free of haze and lint.



Always dry the transparent surfaces carefully after cleaning them.

6. TECHNICAL SPECIFICATIONS

| Dimensions and Weight | Length | Width | Height | Weight |
|-----------------------|------------------|--------------|-----------------|---------------|
| | 38.9 in (987 mm) | 2 in (49 mm) | 6.2 in (157 mm) | 4 lb (1.8 kg) |

Note: Dimensions in inches rounded to the nearest decimal digit.

| Power | Power Supply Type | Range | Voltage Selection |
|-------|----------------------|--------------------------|-------------------|
| | Switching (internal) | 100 to 240 VAC, 50/60 Hz | Auto-ranging |

| Parameter | 120 V, 60 Hz | 230 V, 50 Hz |
|----------------------------------|-------------------|-------------------|
| Consumption | 50 W | 47 W |
| Operating Current | 0.7 A | 0.4 A |
| Power linking current (products) | 8 A (11 products) | 8 A (21 products) |
| Fuse | T 1 A, 250 V | T 1 A, 250 V |

| Power I/O | U.S./Worldwide | UK/Europe |
|------------------------|----------------|------------|
| Power input connector | IEC | IEC |
| Power output connector | Edison | IEC |
| Power Cord plug | Edison (U.S.) | Local plug |

| Light Source | Type | Power | Lifespan |
|--------------|------|-------|--------------|
| | LED | 3 W | 50,000 hours |

| Color | Quantity | Current |
|---------------|----------|----------|
| Tri-color RGB | 12 | 1,000 mA |

| Photometrics | Parameter | Value |
|--------------|-------------------|--------------|
| | Strobe Rate | 0 to 24.5 Hz |
| | Beam Angle | 27° |
| | Field Angle | 45° |
| | Illuminance @ 2 m | 2,245 lux |

| Thermal | Maximum External Temp. | Cooling System |
|---------|------------------------|----------------|
| | 104 °F (40 °C) | Convection |

| DMX | I/O Connectors | Channel Range |
|-----|----------------|------------------------------------|
| | 3-pin XLR | 3, 4, 6, 7, 8, 9, 12, 18, 36 or 41 |

| Ordering | Product Name | Item Code | UPC Number |
|----------|-------------------|-----------|--------------|
| | COLORband PiX USB | 03031170 | 781462215187 |



RETURNS

To get support or return a product:

- If you are located in the U.S., contact Chauvet World Headquarters.
- If you are located in the UK or Ireland, contact Chauvet Europe Ltd.
- If you are located in Mexico, contact Chauvet Mexico.
- If you are located in Benelux, contact Chauvet Europe BVBA.
- If you are located in any other country, DO NOT contact Chauvet. Instead, contact your local distributor. See www.chauvetlighting.com for distributors outside the U.S., UK, Ireland, Mexico, or Benelux.



If you are located outside the U.S., UK, Ireland, Mexico, or Benelux, contact your distributor of record and follow their instructions on how to return Chauvet products to them. Visit our website www.chauvetlighting.com for contact details.

Call the corresponding Chauvet Technical Support office and request a Return Merchandise Authorization (RMA) number before shipping the product. Be prepared to provide the model number, serial number, and a brief description of the cause for the return.

Send the merchandise prepaid, in its original box, and with its original packing and accessories. Chauvet will not issue call tags.

Clearly label the package with the RMA number. Chauvet will refuse any product returned without an RMA number.



Write the RMA number on a properly affixed label. DO NOT write the RMA number directly on the box.

Before sending the product, clearly write the following information on a piece of paper and place it inside the box:

- Your name
- Your address
- Your phone number
- RMA number
- A brief description of the problem

Be sure to pack the product properly. Any shipping damage resulting from inadequate packaging will be your responsibility. FedEx packing or double-boxing are recommended.



Chauvet reserves the right to use its own discretion to repair or replace returned product(s).

CONTACT Us

USA WORLD HEADQUARTERS

General Information – Chauvet

Address: 5200 NW 108th Avenue
Sunrise, FL 33351

Voice: (954) 577-4455

Fax: (954) 929-5560

Toll free: (800) 762-1084

Technical Support

Voice: (844) 393-7575

Fax: (954) 756-8015

Email:

chauvetcs@chauvetlighting.com

World Wide Web

www.chauvetlighting.com

EUROPE

General Information - Chauvet Europe BVBA

Address: Stokstraat 18
9770 Kruishoutem
Belgium

Voice: +32 9 388 93 97

Technical Support

Email:

Eutech@chauvetlighting.eu

World Wide Web

www.chauvetlighting.eu

General Information - Chauvet Europe Ltd.

Address: Unit 1C
Brookhill Road Industrial Estate
Pinxton, Nottingham, UK
NG16 6NT

Voice: +44 (0)1773 511115

Fax: +44 (0)1773 511110

Technical Support

Email:

uktech@chauvetlighting.com

World Wide Web

www.chauvetlighting.co.uk

MEXICO

General Information - Chauvet Mexico

Address: Av. de las Partidas 34 - 3B, Zona
Edo. de Industrial Lerma
Lerma, Mexico C.P. 52000

Voice: +52 (728) 285-5000

Technical Support

Email:

servicio@chauvet.com.mx

World Wide Web

www.chauvet.com.mx

Visit the applicable website above to verify our contact information and instructions to request support. Outside the U.S., United Kingdom, Ireland, Mexico or Benelux, contact the dealer of record.