

# ashford

WHEELS & LOOMS  
INSTRUCTIONS

## e-Spinner

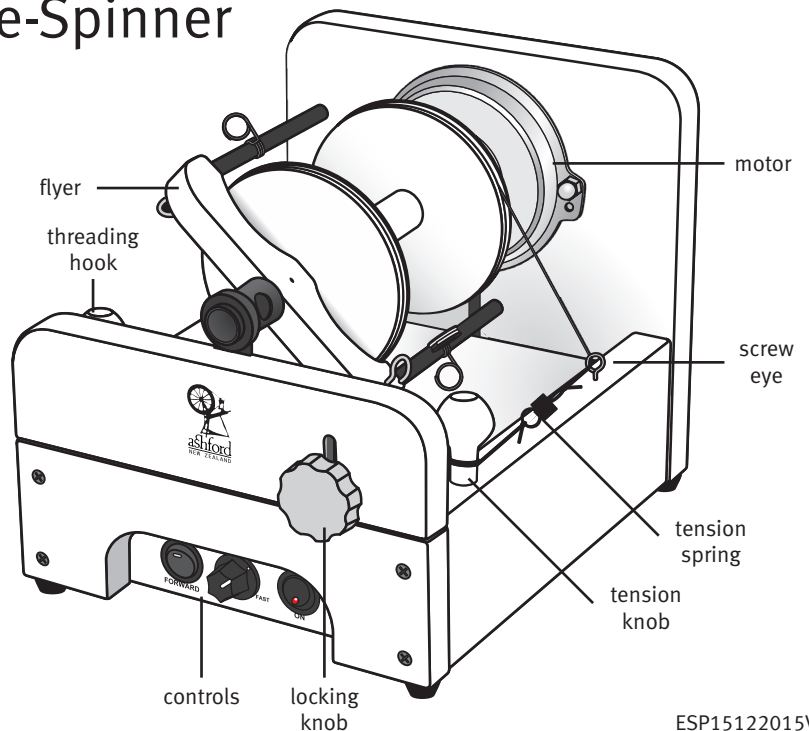
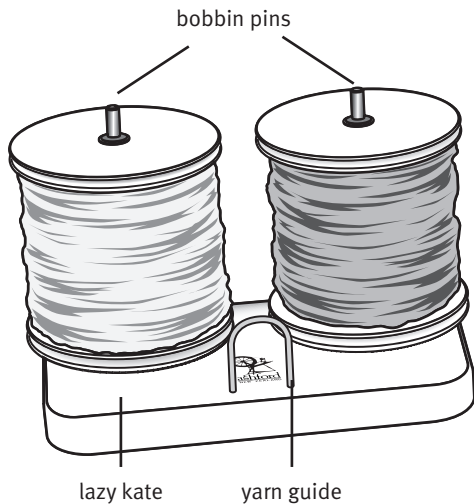

ESP15122015V6

Dear Spinner,

Congratulations on purchasing your new e-Spinner. The e-Spinner continues the tradition of my parents Joy and Walter, to design and make spinning wheels to meet the needs of spinners. There are now over 500,000 Ashford Spinning wheels in use around the world and we are sure you will enjoy using your new e-Spinner. Thank you for choosing Ashford.

Happy spinning,

Elizabeth and Richard Ashford

### Finish

Your e-Spinner has been lacquered prior to assembly. If desired Ashford Wax Finish may be applied to further enhance it's appearance.

### Assembly

1. Thread the 2 hooks into the pilot holes in the flyer base.
2. Squeeze and slide the stainless steel yarn guides onto the flyer arms.
3. Locate the bolt through the slot in the front and secure with a washer and locking knob.  
Warning! - Ensure the head of the bolt fully engages the slot in the latch before switching on. If not, the front could open and release the flyer, which could be damaged.
4. Thread the screw eye with the tension spring attached into the pilot hole in the left hand side.
5. Thread the screw eye into the pilot hole in the right hand side.
6. Apply a drop of oil to the flyer spindle and slide the bobbin on.

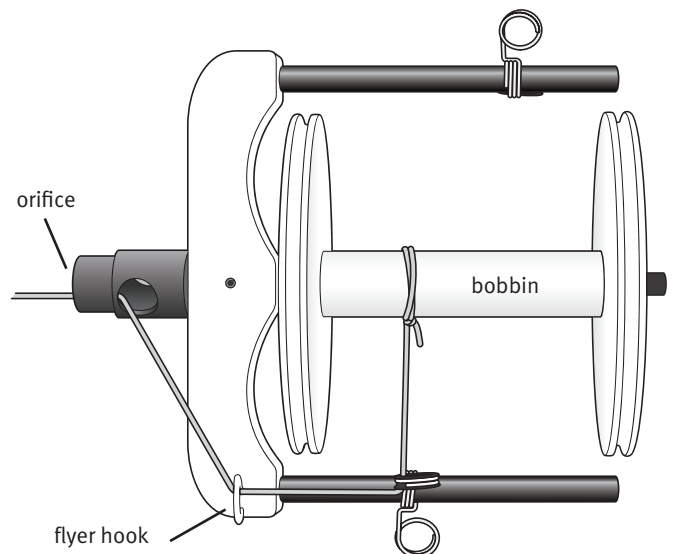
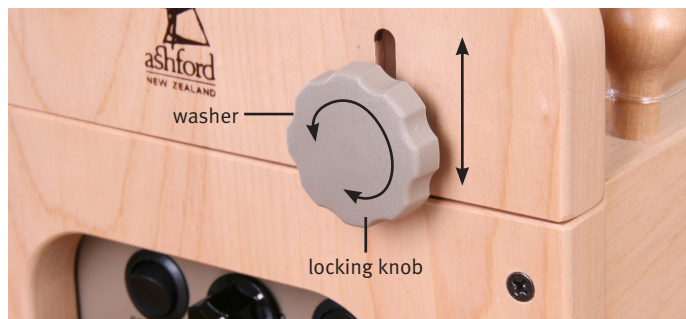

7. Loosen and lift the locking knob, then open the e-Spinner front. As the shaft has minimal clearance on the front bearing, until it has bedded in, it may be necessary to gently pull on the bearing at the same time as opening the front.
8. Slide the flyer shaft into the flexible nylon drive bush on the motor shaft, rotating it until the shaft slides on and fully engages.

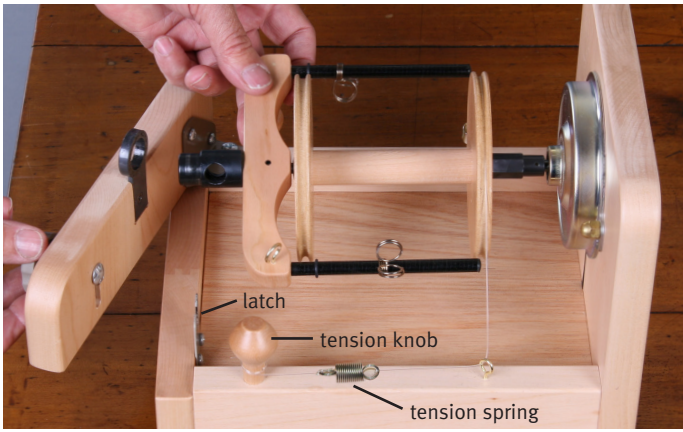

9. Lift the locking knob, align the flyer orifice with the bearing, close the e-Spinner front, slide the locking knob down checking the head of the bolt engages the slot and tighten.
10. Tie the nylon brake band to the tension spring attached to the screw eye, place it in the groove in the bobbin and thread it through the screw eye.
11. Cut the nylon brake band 10cm - 4" from the screw eye and tie to the second tension spring. Tie the second piece of nylon brake band to the other end of the tension spring, thread it through the tension knob and tie a knot. Locate the tension knob in the tapered hole and twist the tension knob until the springs just start to stretch.
12. Locate the threading hook into the hole by the hinge.

#### Lazy Kate

1. Tap the 2 bobbin pins into the holes in the Lazy Kate base.
2. Gently squeeze the ends of the yarn guide together and push it into the 2 holes in the Lazy Kate base.

#### Power Pack

Your e-Spinner 12v power pack is supplied with optional face plates. New Zealand / Australia, UK, Europe / Scandinavia and USA / Japan To change the face plate to suit your country, push the locking pin down and twist anti-clockwise. Locate the correct face plate onto the power supply and twist clockwise until it is locked securely in position.

Locate the power cord into the hole in the rear of the e-Spinner, check the ON/OFF switch is off and the SPEED dial on SLOW. Insert the power pack into a main wall plug and switch on.

Note: the power pack will accept an input of 100-240v.

#### Controls

- A. FORWARD/REVERSE: FORWARD for spinning, REVERSE for plying. Do not reverse the direction without stopping the motor with the ON/OFF switch.
- B. SPEED: Start on SLOW and increase gradually until the correct speed is achieved.
- C. ON/OFF: Always switch the e-Spinner OFF when you want to stop. Check the red LED light is off before you leave your e-Spinner.

Note: The red LED light indicates the status of your e-Spinner.

**Constant on** – your e-Spinner is running normally.

**Flashing short on / long off** – e-Spinner is in standby. The speed is set to ZERO or the optional foot switch is OFF.

**Flashing long on / short off** – the motor is working too hard. Reduce the brake band tension or apply a drop of oil to the front bearing.

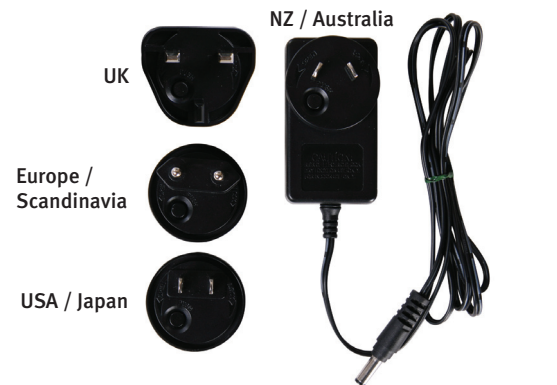

#### Safety

1. Always unplug the power pack from the wall when not in use.
2. Do not leave the e-Spinner without switching it OFF at the ON/OFF switch.
3. Do not use your e-Spinner in damp or wet conditions.
4. Never open the electronic compartment without first disconnecting it from the power supply.

#### Accessories

- Available from your local Ashford Dealer:
- 12v DC power cord and cigarette lighter plug so you can spin away from home in your car or caravan.
- Bobbins - Ashford Jumbo single drive bobbins.
- Maintenance kit - Includes a bottle of Ashford Spinning Wheel Oil, tension springs and brake band.
- Foot operated ON / OFF switch. Plug into the socket in the rear of your e-Spinner so you can turn your e-Spinners on or off with the tap of your foot. Only available for e-Spinners with an appropriate socket shipped since December 2015.

#### Lubrication

- We recommend Ashford Spinning Wheel Oil be regularly applied to the front flyer and bobbin bearings.
- A drop of Vaseline or grease may be applied to the motor drive bush to make bobbin changing easier and minimize noise.
- The bobbin and flyer must revolve freely and independently of each other.
- The ball bearings in the motors may be noisy for the first 5-10 minutes as they "run-in" and the grease is dissipated evenly.

#### Spinning

Tie a piece of yarn, called a leader, about 1 metre (1 yard) long to the bobbin, loop it through the sliding flyer hook, around the hook in the flyer base and through the orifice - Have your prepared fibres ready to spin.

Check the FORWARD/REVERSE switch is on FORWARD and the SPEED control is on SLOW. Switch the ON/OFF switch to ON. Gradually turn the SPEED control clockwise until the flyer starts to turn slowly.

Allow the leader to start feeding in and commence drafting the prepared fibres onto it.

Adjust the SPEED control and tension knob to achieve a comfortable speed and take up. Use the ON/OFF switch to stop the motor when moving the position of the yarn guide. This will ensure you continue at the same speed.

To change bobbins turn the motor off using the ON/OFF switch, lift the brake band off the bobbin, loosen and lift the locking knob, open the front and remove the flyer and bobbin. After replacing the bobbin and flyer check the bolt has engaged the slot in the latch and tighten the locking knobs. Refer to the "Learn to Spin" booklet for more hints on spinning. \* For further spinning information refer to "The Ashford Book of Hand Spinning", a 116 page book full of ideas and inspirations for spinners.

**Orifice Reducer Bush** - The nylon bush may be inserted into the flyer orifice to reduce the diameter. This is beneficial when spinning finer yarns as it will help prevent the yarn vibrating. By spinning the yarn at about a 45 degree angle to the orifice the vibration will almost be eliminated. When plying or spinning thick yarns, remove the bush.

#### Ashford Handicrafts Limited

Factory and Showroom: 415 West Street  
 PO Box 474, Ashburton 7700 New Zealand  
 Telephone 64 3 308 9087 Facsimile 64 3 308 8664  
 Email: sales@ashford.co.nz Internet: www.ashford.co.nz

#### Ashford Guarantee

Thank you for purchasing this Ashford product. In the unlikely event there is any fault in manufacture we will replace the item. To validate our guarantee please visit our website or write to us.